

INSTALLATION INSTRUCTIONS
PLEASE READ ALL INSTRUCTIONS BEFORE PROCEEDING

These valves are for use on fuel tanks to comply with the new CARB and EPA standards and meet the requirements of U.S.C.G. Safety Standards (July 31, 2011) for 40 CFR Parts 9, 60, 80 et al. (Control of Diurnal Emissions From Nonroad Spark-Ignition Engines and Equipment).

Note: Installer-supplied mating components must be CARB, EPA and ABYC compliant.

Fill Limit Vent Valve (FLV) Series 0586F

Note: The ullage depth is set by the tank manufacturer or OEM builder and cannot be changed. In order to maintain compliance with the EPA and CARB requirements, these valves that set the ullage depth cannot be interchanged with different depth valves.

Tank Vent Valves (TVV) Series 0588F

1. These valves are designed to mount on aluminum or plastic tank surfaces.
2. Select your mounting location. Cut out mounting template attached. The template can first be utilized to form an installer-supplied mounting gasket.
3. Then attach the template to the mounting surface and drill 1-1/2" diameter hole for the valve.
4. Mark and drill mounting screw holes for #8 mounting screws. Place the gasket onto the mounting surface. Make sure to orient the hose barb in the proper direction to attach the vent line.
5. Attach 5/16" vent hose onto hose barb and tighten using a hose clamp in accordance with ABYC Fuel System Vent Hose Clamping Standards (H24 Table 3).



Fig. 0588F00

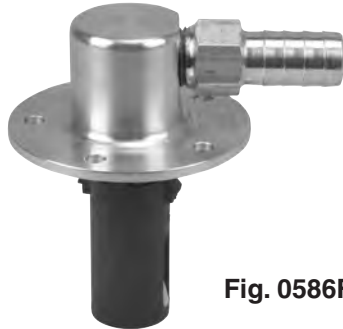

Fig. 0586F

Cat Nos:

- 0586F00012 - 1/2 Ullage
- 0586F00034 - 3/4 Ullage
- 0586F00118 - 1-1/8 Ullage
- 0586F00112 - 1-1/2 Ullage

*The above referenced standards can be obtained from:

- | | | |
|---|---|--|
| (1). American Boat & Yacht Council, Inc.
613 Third Street, Suite 10
Annapolis, MD 21403 | (2) U.S. Coast Guard
Washington, D.C. 20593
(or your local C.G. office) | (3). E.P.A.
401 "M" Street S.W.
Washington, D.C. 20460 |
|---|---|--|



PERKO, INC.
16490 N.W. 13th Avenue
Miami, FL 33169-5707
www.perko.com

Mounting Template
Fig. 0586F Fill Limit Vent (FLV)
Fig. 0588F Tank Vent (TVV)

Drill for #8 Mounting Screws (5 Places)
on a 2-1/8" Bolt Circle

Note: SAE bolt circle "not"
equally spaced

