

The above lights are designed for use on sail or power driven vessels under 20 meters (65.6 ft.) in length operating on a nominal 12 volt system. In order to comply with '72 COLREGS and the U.S. Inland Rules, the following must be adhered to:

### MOUNTING INFORMATION

Read all instructions before proceeding.

- These instructions show the orientation of each light. For proper light selection, positioning and configuration, refer to A.B.Y.C. Standard A-16\*, the '72 COLREGS and the U.S. Inland Navigation Rules\*. These lights are supplied complete with 12 volt L.E.D.'s. L.E.D. lights have no user serviceable parts.
- These lights are designed to be mounted on a horizontal surface.
- Cat. Nos. 1683 and 1696 series: These lights are furnished for mounting such that the long dimension of the mounting base is parallel to the fore-aft centerline of the boat.
  - Draw a 4 inch long reference line through the center of the selected mounting location and parallel to the fore-aft centerline of the boat.
  - Cut out the mounting template below. Tape it on the mounting surface such that the reference line (drawn above) is directly underneath the reference line marked on the template.
  - Drill 2 holes through the template to accommodate #8 round head mounting screws. Drill one 3/8 inch hole to accommodate the electric wiring. (Proceed with instruction #5 below).
- Cat. No. 1697 Series: This light is furnished with a 3/4 inch tube and is designed to be mounted vertically into a 3/4 inch hole.
- IMPORTANT:** If wiring light into a new installation (or an installation with a new switching arrangement), use wiring diagram (A). If replacing a similar two compartment light (incandescent combination masthead/anchor) light, use wiring diagram (B) with Perko Cat. No. 1680DP012V 12 volt converter module or reswitch the navigation lights to match wiring diagram (A). Direct wire to wire replacement of an older style incandescent light with this new style L.E.D. light will not work.

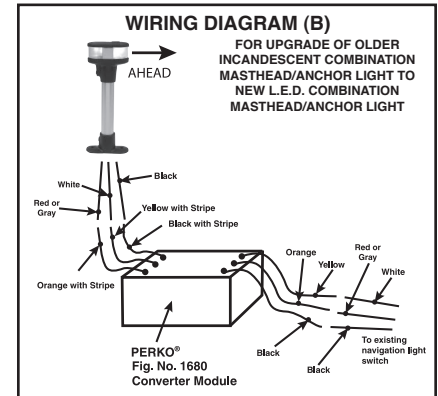
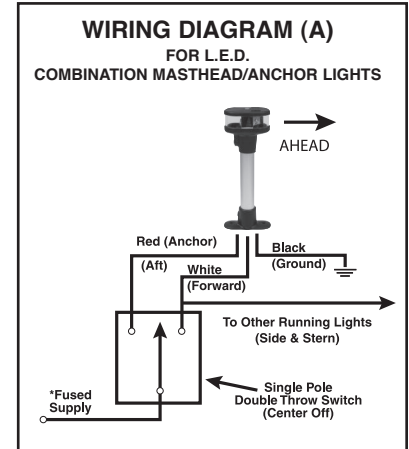

Attach supply connections to the light making sure to wire in accordance with both A.B.Y.C. Standard E4\* and U.S. Coast Guard Safety Standards for Boat Electrical Systems (33 CFR 183)\*. The supply leads are coded as follows:

- WHITE: Forward compartment only (masthead light) positive lead supply.
- GRAY or RED: Forward compartment and aft compartment (anchor light) positive lead supply.
- BLACK: Negative lead supply.

Electrical connections are to be made such that only the forward compartment (masthead light) is energized with the other running lights (sidelights, stern lights etc.) while underway. Both compartments are energized simultaneously by themselves to create the all-round (anchor) light.

- Mount the base in accordance with both the template and instruction #7 below.
- Make sure the top of the light is vertical during operation (see illustration) and the arrow on the top cover points ahead (not astern), with the reference mark parallel to the fore-aft centerline of the boat.

\*The above referenced standards can be obtained from:

- American Boat & Yacht Council, Inc.  
613 Third Street, Suite 10  
Annapolis, MD 21403
- U.S. Coast Guard  
Washington D.C. 20593  
(or your local C.G. office)

### MOUNTING TEMPLATE

